

# CHAPTER/REGIONAL TECHNOLOGY AWARD - SHORT FORM

## 1. Category - Check one and indicate New, Existing, or Existing Building Commissioning (EBCx)

Commercial Buildings  New  Existing or  EBCx

Institutional Buildings:

Educational Facilities  New  Existing or  EBCx

Other Institutional  New  Existing or  EBCx

Health Care Facilities  New  Existing or  EBCx

Industrial Facilities or Processes  New  Existing or  EBCx

Public Assembly  New  Existing or  EBCx

Residential (Single and Multi-Family)

2. Name of building or project: \_\_\_\_\_

City/State: \_\_\_\_\_

3. Project Description: \_\_\_\_\_

Project Study/Design Period: \_\_\_\_\_ to \_\_\_\_\_  
Begin date (mm/yyyy) End date (mm/yyyy)

Percent Occupancy at time of submission: \_\_\_\_\_

4. Entrant (ASHRAE member with significant role in project):

a. Name: \_\_\_\_\_  
Last First Middle

Membership Number: \_\_\_\_\_

Chapter: \_\_\_\_\_

Region: \_\_\_\_\_

b. Address (including country): \_\_\_\_\_

\_\_\_\_\_ City State Zip Country

c. Telephone: (O) \_\_\_\_\_ d. Email: \_\_\_\_\_

e. Member's Role in Project: \_\_\_\_\_

f. Member's Signature: \_\_\_\_\_

5. Engineer of Record: \_\_\_\_\_

By affixing my signature above, I certify that the information contained in this application is accurate to the best of my knowledge. In addition, I certify that I have discussed this entry with the owner and have received permission from the owner to submit this project to the ASHRAE Technology Awards Competition.

**Illinois Institute of Technology Research Institute  
A Subsidiary of Illinois Institute of Technology  
Preheat System Replacement**

**ASHRAE Illinois Chapter  
Excellence in Engineering Awards 2016**

**Spagnolo Enterprises, Ltd.  
Park Ridge, Illinois**

**Engineers**

**Philip J. Spagnolo, P.E.  
Brian Zellmer**

## **Project Overview**

Illinois Institute of Technology Research Institute (IITRI) occupies a laboratory building at the main campus of Illinois Institute of Technology (IIT) in Chicago, Illinois. The building includes two BSL-3 labs, many intox labs, analytical chemistry labs and a significant vivarium. The building has undergone many renovations over its lifetime with some less than positive results. Spagnolo Enterprises, Ltd was contacted by IIT, the operator of the building for IITRI in May of 2014 to evaluate the continuous failures of steam preheat coils in many of their 100% outside air, air handling units serving the building.

The LSR building, constructed in the early to mid-1950's, is a two story building with a partial basement. The overall floor area is approximately 100,000 square feet and is ventilated at a rate of 10 to 15 air changes per hours depending on the use. 125 psig steam is sold and delivered to the building from the campus boiler plant. The steam is distributed at various pressures to varying loads throughout the building. This project began by evaluating four preheat coils that continued to fail each year of service as a result of 100 psig steam being supplied directly to the coils. These coils included face and bypass dampers and no control valves. The live steam eroded coil tubes annually resulting in undesirable conditions. Furthermore, the coils were left active year round with no shut off available, continuously wasting energy. This investigation led to further review of the steam and condensate systems where we found higher pressure condensates being blended with lower pressure condensate and more failed equipment.

## **Project Objective**

- Replace the existing steam coils that continue to fail
- Improve the environmental conditions
- Reduce operating expenses including continuous repairs and maintenance
- Reduce the utility costs

The simple fix to the problem of failing coils would have been to replace the coils and reduce the pressure of steam entering the coils. Control valves would also benefit the facility. However, after further evaluation of the steam and condensate piping systems, it was determined that the modifications required were so significant and physically challenging that an alternative method was necessary. We immediately evaluated physical constraints including abandoned equipment, piping and ductwork, operating methods and costs, and reports of ongoing concerns. The solution was to look at a holistic approach for the entire

building which led to the design of new steam to hot water converters and distribution to service all of the preheat needs for the lab building.

The design included pulling back steam distribution piping to the source, installing multiple heat exchangers to serve the loads and offer redundancy, installing distribution pumps and control valves at each load and integrating the system into the building management system. Faulty steam and condensate piping was removed to eliminate dead legs and multiple condensate pressures being combined.

## **Project Results**

### **1. Energy Efficiency:**

Rather than allowing the 125 psig steam to flow through the face and bypass coils continuously year round, erode the coil tubes and add heat to the cooling coils, we elected to replace the steam coils with hot water/glycol coils with pressure independent modulating control valves. The revision allows for improved temperature control to setpoint during the heating season including an outdoor air reset schedule for the fluid, disabling of the preheat system during outdoor air temperatures above 45 degrees Fahrenheit, precise control of the heat exchanger output temperatures with one third two third industrial grade control valves sized for increased pressure drops to avoid the need for pressure reducing stations and increased energy savings. The savings experienced for a five month period of this year compared to the last heating season of the same months was \$220,775.26. IITRI pays IIT Power for their steam consumption.

### **2. Indoor Air Quality:**

Not Applicable. This submittal is limited to coil replacements and the installation of a new preheat heat exchanger system to serve the coils. Better control of the preheat coils has resulted in improved environmental conditions within the building. In the past, the building depended on cooling coils to cool the air that had been over heated from the preheat coils.

### **3. Innovations:**

We took advantage of two newer technologies on this project. Both involved control valves. First, we used industrial grade steam control valves with pneumatic actuators and digital controllers. Instead of reducing steam pressure at conventional pressure

reducing stations and passing it through control valves at the heat exchangers, we selected control valves with higher pressure drops which resulted in smaller valves, better modulation or authority and better control. We included valves selected for one third the capacity and two thirds the capacity both with 125 psig steam entering.

The other innovation included the use of pressure independent control valves for the heating coils at the air handling units. The pressure independent valves offer tighter control at varying system pressures. We are assured precise flow as system pressure modulates therefore preventing the steam control valves from hunting and or over shooting their setpoints.

#### **4. Operations and Maintenance:**

The new system reduced the quantity of steam traps in the system, eliminated the need for condensate routed on the roof along with electric heat tape for freeze protection, the electric condensate pumps were removed as they continued to fail with elevated condensate temperatures and most importantly the continuously failing coils were replaced with new glycol water coils. The pumps initiate automatically based on outdoor air temperatures, they rotate weekly for even wear time as do the heat exchangers. All new equipment is monitored and adjustable from the building management system.

#### **5. Cost Effectiveness:**

The cost to install the new heat exchangers, pumps, coils, and piping distribution system was \$763,987.00. With only five months of confirmed savings of \$220,775.26 the simple payback is less than 3.5 years. We are tracking costs for the year to determine final savings. As the values are shared with us, we will continue to adjust the economic analysis.

#### **6. Environmental Impact:**

The new installation reduces water consumption at the main boiler plant. We are now able to return all condensate to the central plant. Elimination of trapped condensate piping allows us to get all condensate sorted, flashed, recovered and returned to the boiler plant for reuse.

AHU PREHEAT COILS ON ROOF

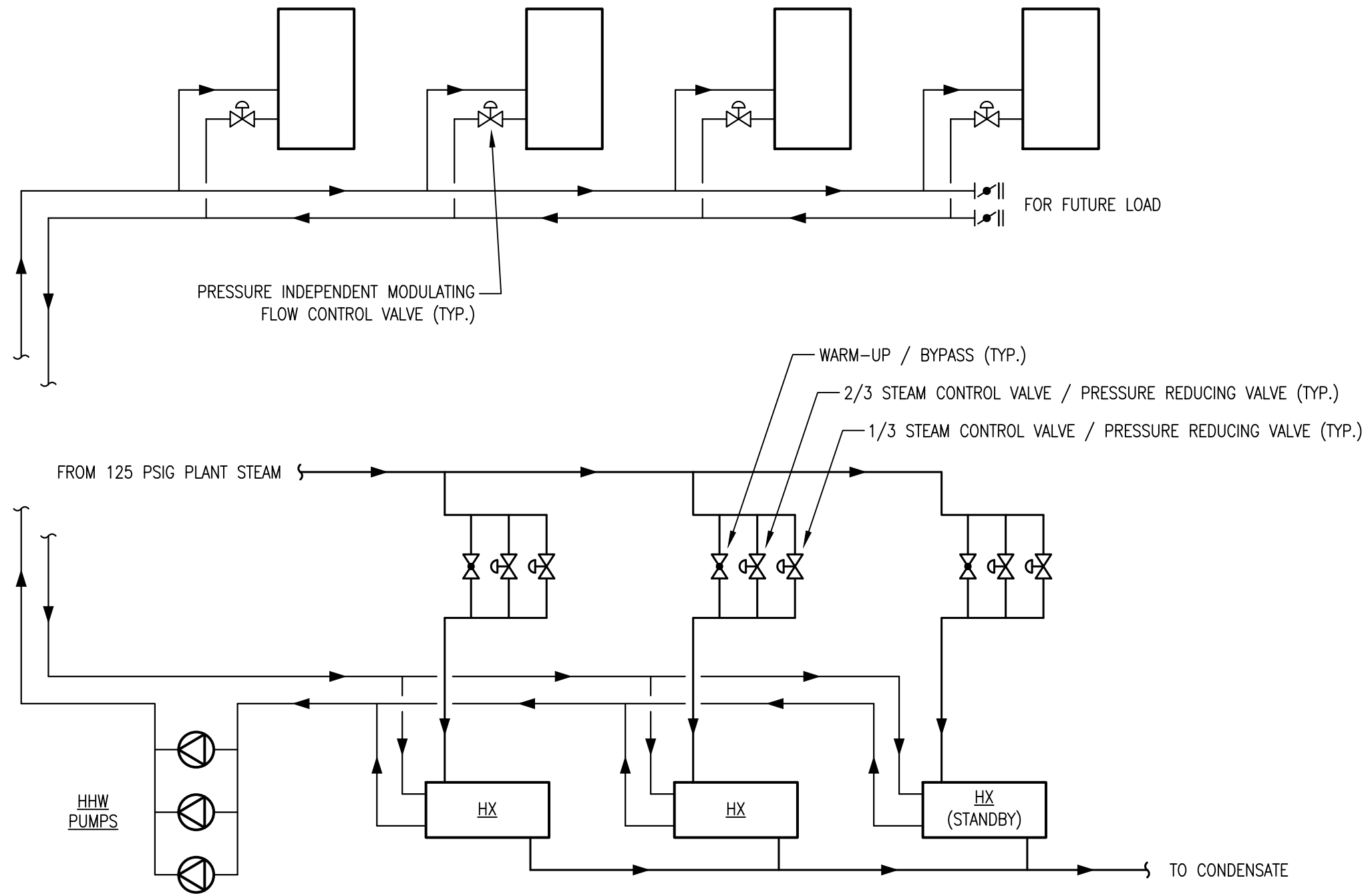

**LSR BUILDING  
HVAC HEATING SYSTEM  
EFFICIENCY IMPROVEMENTS**